

PERIOD WOMAN MANNEQUINS

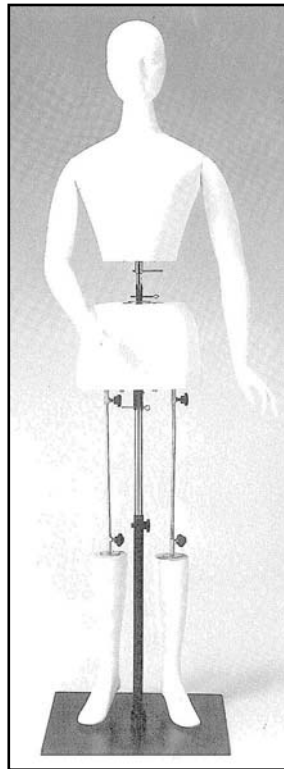

THE 18TH CENTURY

KCIM-1

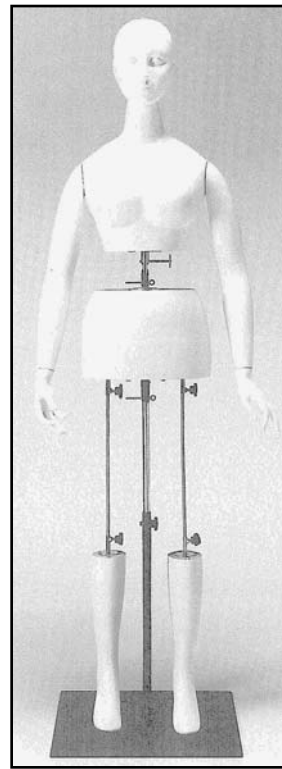

THE 19TH CENTURY

KCIM-3

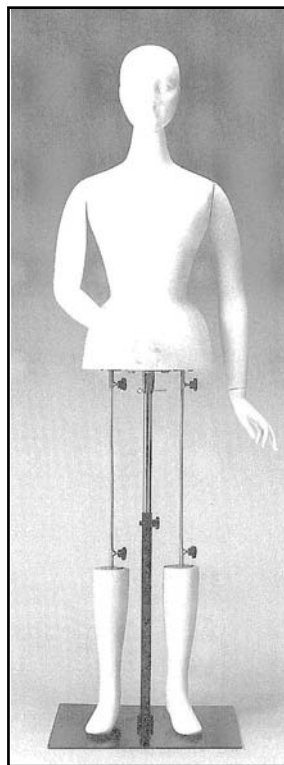

EMPIRE AGE(Approx.1800~1820)

KCIM-2



BELLE EPOQUE(Approx.1895~1910)

KCIM-4

Wacoal Corp.

103, Shichi-jo Goshonouchi Minamimachi, Shimogyo-ku, Kyoto, 600-8864, JAPAN
Phone +81-(0)75-321-9221 FAX +81-(0)75-321-9219

THE 18TH CENTURY

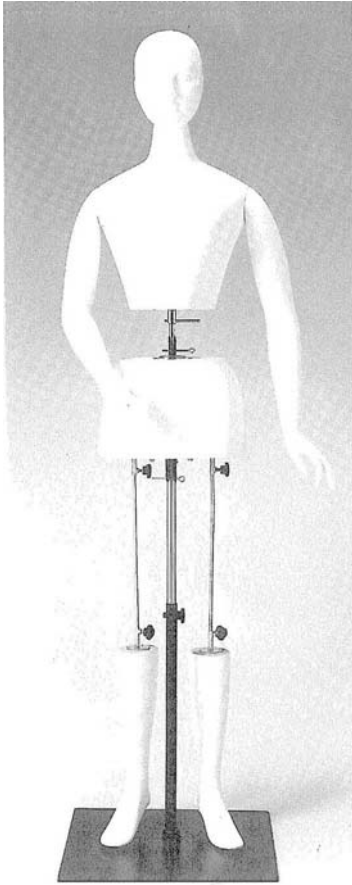

KCIM-1

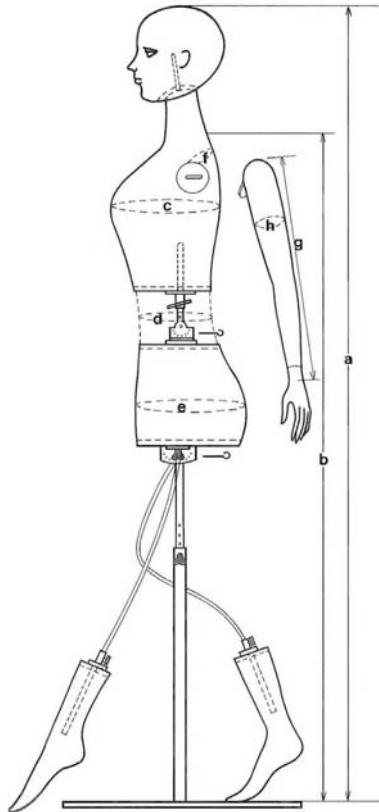

Standing Pose

SIZE (cm)

- a 170.0 - 199.0
- b 144.0 - 173.0
- c 85.0
- d 56.0
- e 90.0
- f 34.0
- g 55.0
- h FIX 24.5 FLEX. 21.0

Material

Body, head and feet are made of Fiber Reinforced Plastic(FRP). We have two types of arms and hands, FRP-made and flexible form polyurethane. You can combine those parts freely. Legs are made of aluminum, which you can curve freely. Man-like movement. Stand base is steel-made.

Sitting Pose

SIZE (cm)

- a 89.0
- b 37.0 - 43.0
- c 54.0

Notes:

You can make a sitting mannequin of 18c. 19c. by adding optional thigh parts.

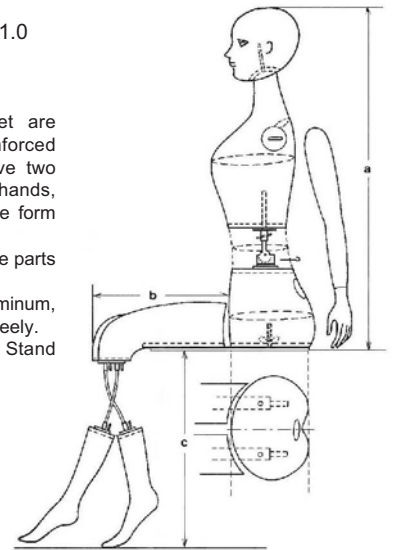

ITEM	NO.
Body with joint parts	BODY-1

ITEM	NO.
Head parts	HEAD

ITEM	NO.
Stand and base	BASE

ARMS and HANDS	
ITEM	NO.
FRP (Right, Straight)	AFRS
FRP (Left, Straight)	AFLS
FRP (Right, Bent)	AFRB
FRP (Left, Bent)	AFLB
Polyurethane (Right)	AURF
Polyurethane (Left)	AULF

ITEM	NO.
Leg of sitting pose	SITT

Feet (pair)	
ITEM	NO.
Low heel	FOOL
High heel	FOOH
Tip toe	FOOT

EMPIRE AGE (Approx. 1800 - 1820)

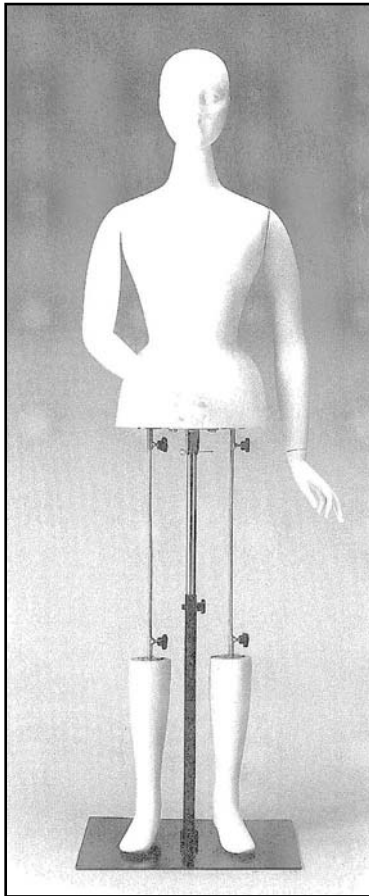

KCIM-2

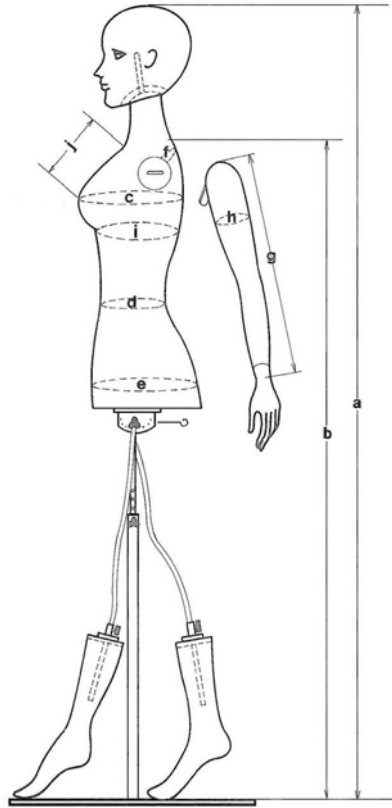

SIZE (cm)

- a 156.0 - 180.0
- b 130.0 - 154.0
- c 82.0
- d 52.5
- e 87.0
- f 33.0
- g 55.0
- h FIX 25.0 FLEX. 21.0
- i 67.0
- j 11.5

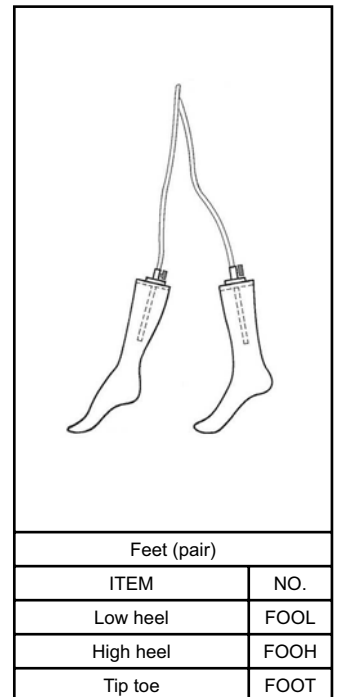
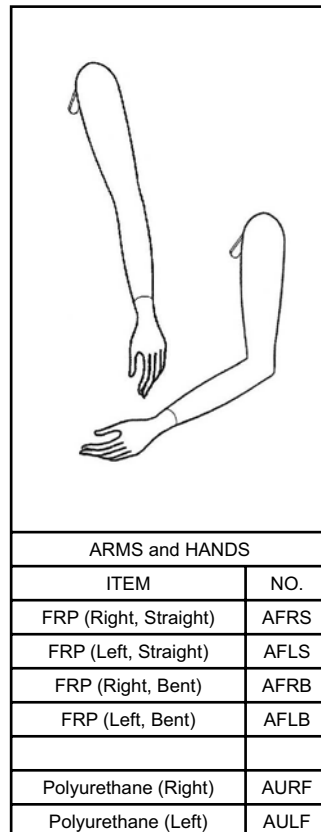
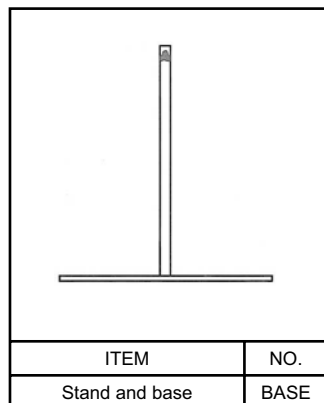
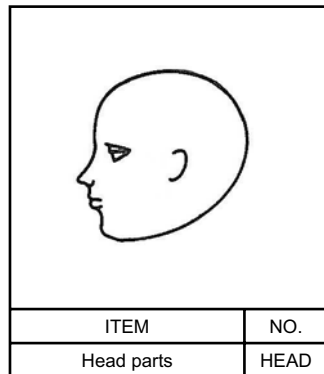
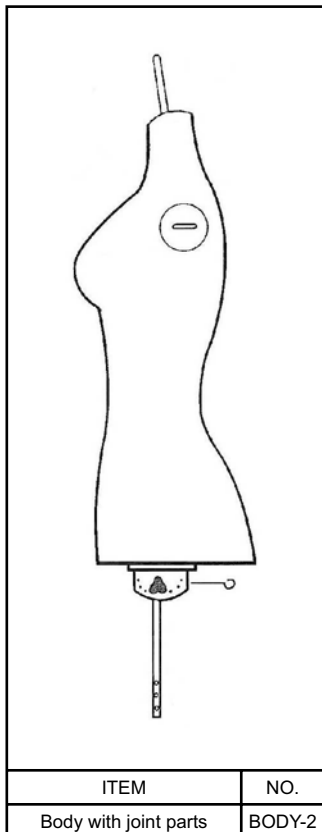

THE 19TH CENTURY

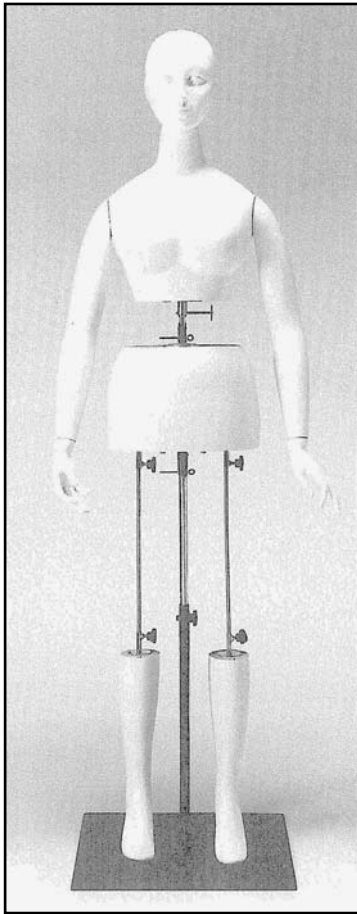

KCIM-3

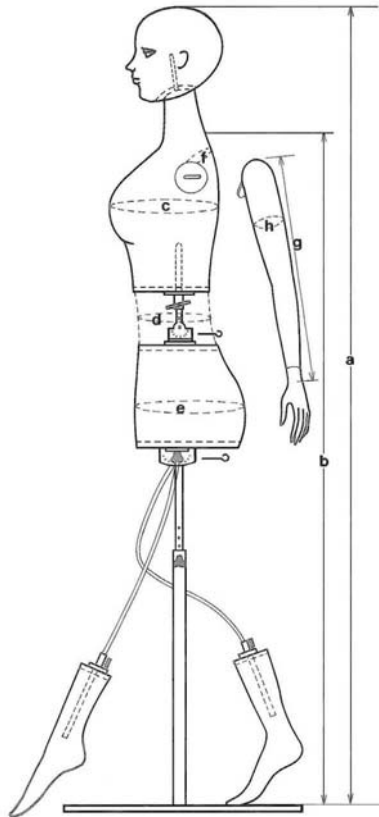

Standing Pose

SIZE (cm)

- a 167.0 - 199.0
- b 141.0 - 173.0
- c 85.0
- d 54.0
- e 94.0
- f 35.0
- g 55.0
- h FIX 25.0 FLEX. 21.0

S size (only upper body)

- c 79.0
- f 31.0

Sitting Pose

SIZE (cm)

- a 89.0
- b 37.0 - 43.0
- c 54.0

Sitting pose

You can make a sitting mannequin of 18c. 19c. by adding optional thigh parts.

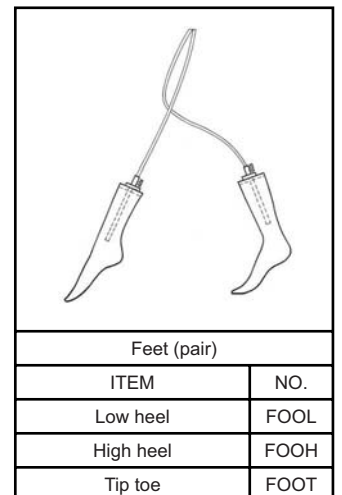
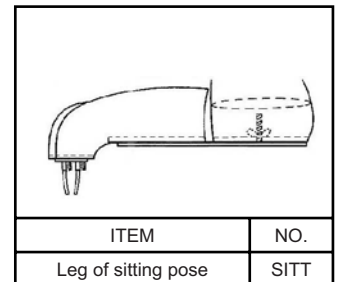
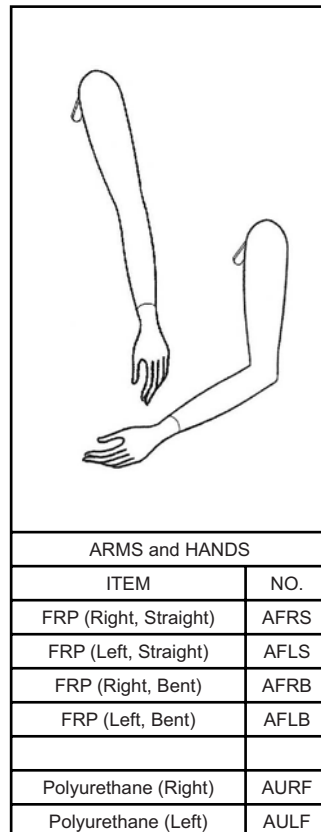
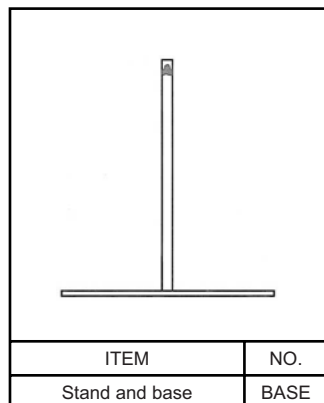
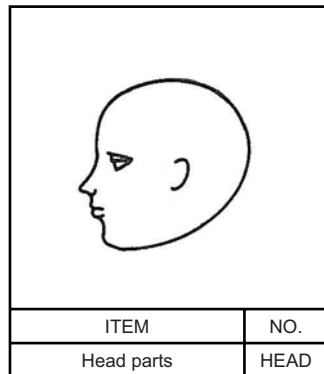
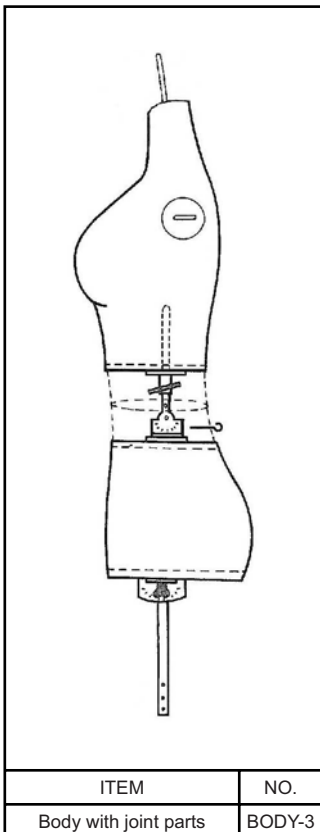
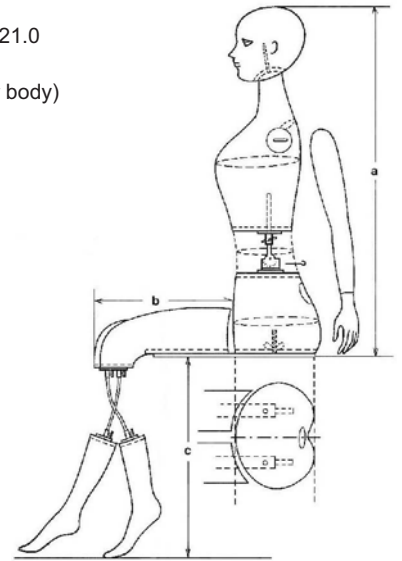

BELLE EPOQUE (Approx. 1895 - 1910)

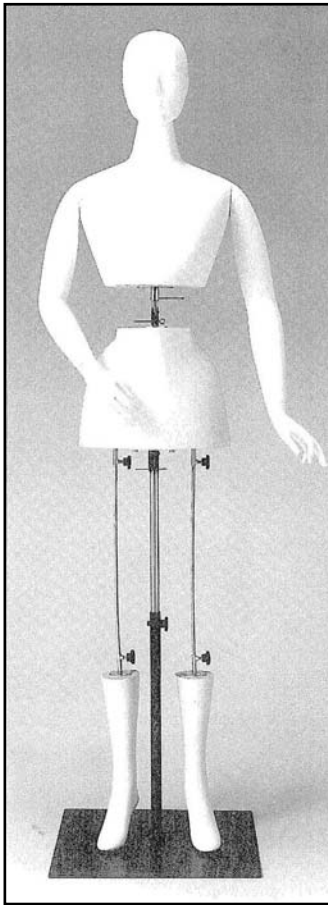

KCIM-4

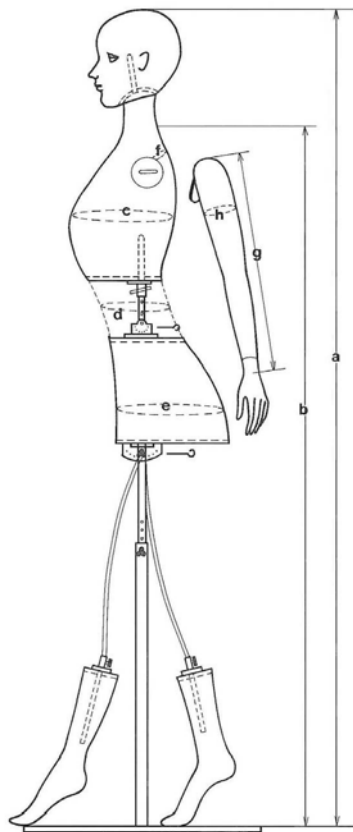

SIZE (cm)

M size

a 167.0 - 199.0

b 141.0 - 173.0

c 85.0

d 54.0

e 94.0

f 35.0

g 55.0

h FIX 25.0 FLEX. 21.0

S size

a 167.0 - 199.0

b 141.0 - 173.0

c 78.0

d 47.0

e 86.0

f 33.0

g 55.0

h FIX 25.0 FLEX. 21.0

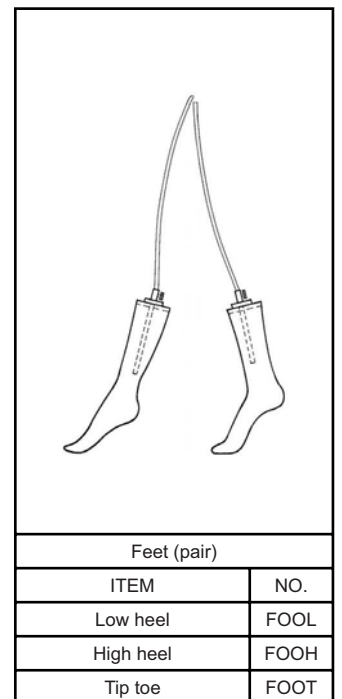
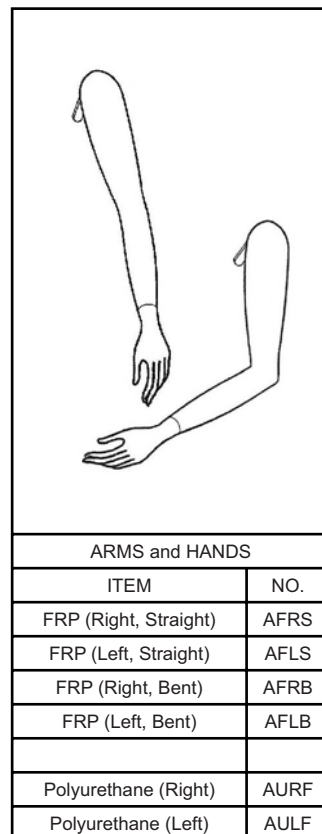
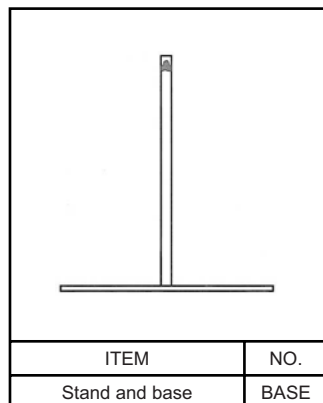
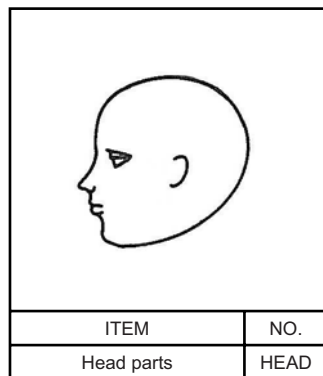
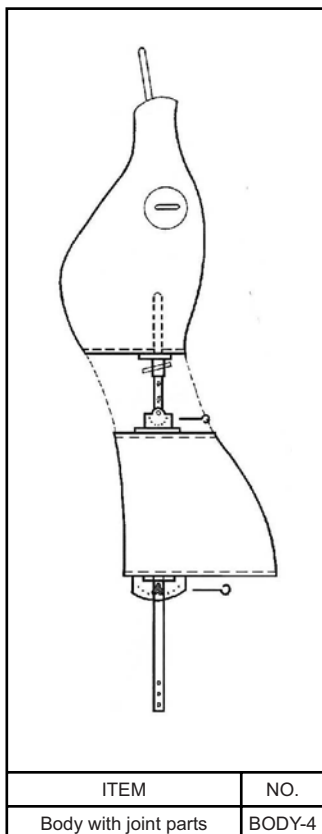

The 18th Century Male Mannequin

Through the development of innovative metal fittings at the neck, waist, thigh, knee, and arm, the KCI male mannequin can be positioned to present the lifelike posture and suggested movement of a human being. Essential to the safe display of period costume, KCI male mannequins can accommodate a wide range of sizes with the adjustable metal fittings at the waist, thigh and knee.

A flexible metal pipe in the place of the arm and thigh make subtle articulation possible.

Note: The leg through which the support pole runs (right or left side optional) cannot be adjusted.

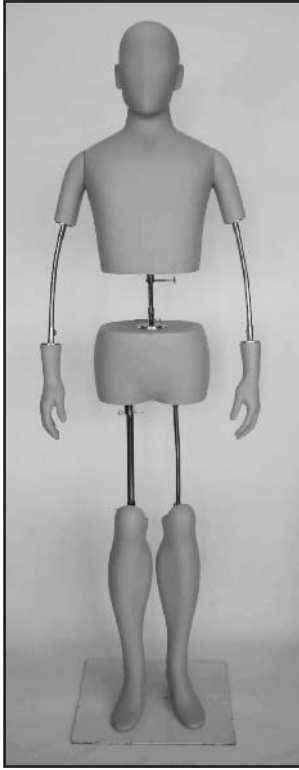

KC I M-M1

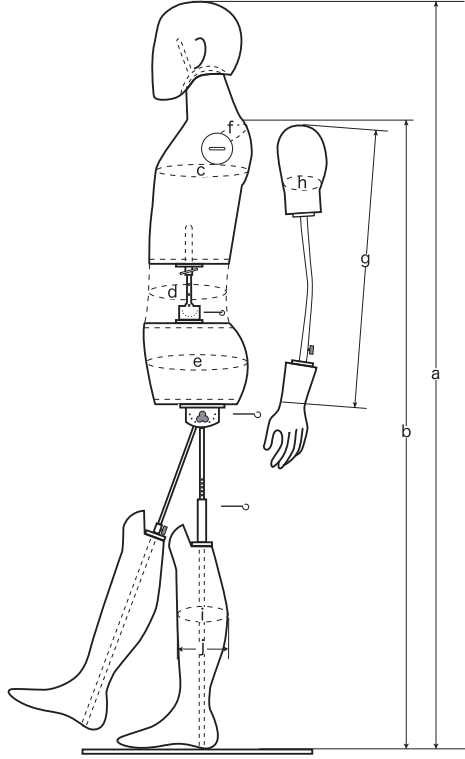

SIZE_(cm)

- a 162.0~194.0
- b 137.0~169.0
- c 90.0
- d 70.0
- e 91.0
- f 35
- g 49.0~68.0
- h 22.5
- i 39.0
- j 13.0

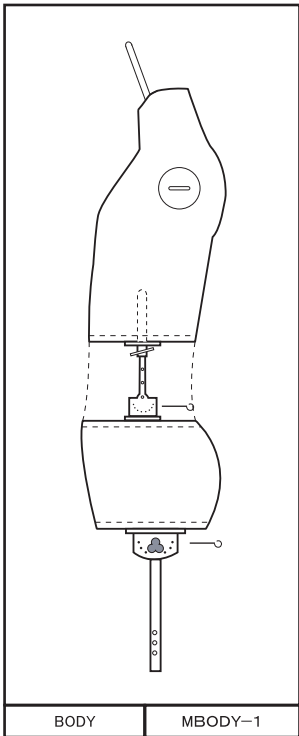

The Torso:
The waist can be lengthened or shortened by the placement of the vertical pin. The front to back angle of the upper torso can be adjusted by the placement of the radial pin.

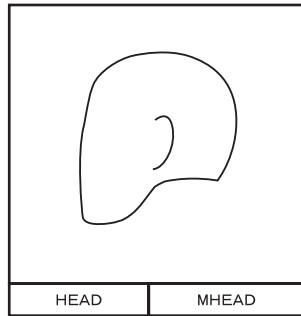

The Head:
The neck can be rotated 360 degrees
The chin can be angled up or down.

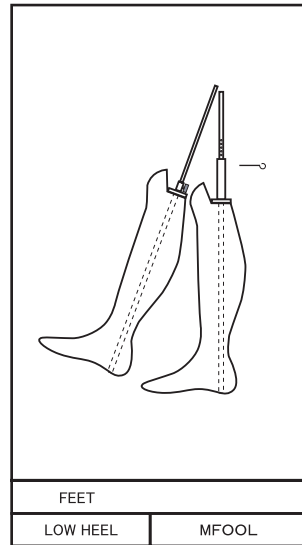
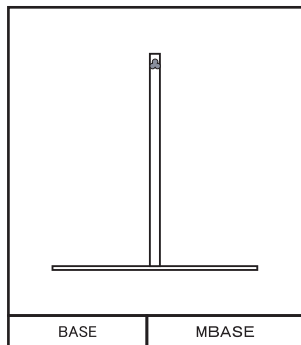

The Feet:
The feet can be pivoted from the upper thigh and the knee, by small degrees, to turn in or out.

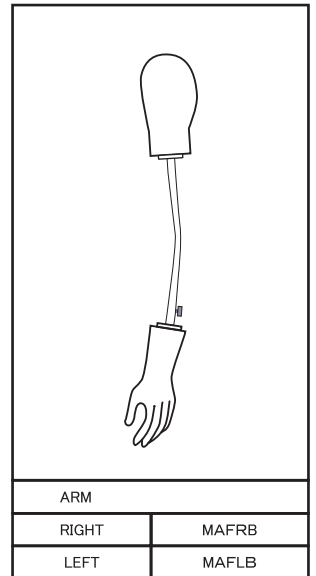

The Arm:
The arm can be rotated 360 degrees at the shoulder
The length of the arm is adjustable at the wrist.